



SVR catégorie 'B'

FRP class 'B'

SVR catégorie "B"

SVR (stratification verre résine)

MATIERE DE BASE

Résine : Résine vinylester, Déarakane 411-350 DOW CHEMICAL
Autre type de résine sur demande .

Tissus : Fibre de nature E
Ensimage type plastique (M1)
Liant des fibres type poudre

Charge : Possibilité d'ajouter un anti-UV
Possibilité de teinter la dernière couche sur demande

PROCEDE

Moulage au contact par enroulement de bandes conforme aux prestifications de l'UIC N°7

DIMENSIONS

Les tubes et accessoires sont fabriqués suivant les standards
ATOCHEM , RHONE POULENC , SOLVAY :

SVR catégorie "B"

FRP (Fibreglass Reinforced Polyester)

BASE MATERIAL

Résin : vinylester resin,DOWN CHEMICAL Déракane 411-350
other types of resin on request

Cloth : Nature E
plastique (M1) type oiling
Powder type fibre binder

Filler : Possibility to adding an anti-UV
Possibility to tinting the last layer on request .

PROCESS

Contact moulding by strip wrapping in accordance with the requirements of UIC N° 7..

DIMENSIONS

The tubes and accessoires are made to ATOCHEM , RHONE POULENC , SOLVAY :

SVR catégorie "B"

<u>ELEMENTS</u>		<u>NUMERO STANDARD</u>
<u>Au contact</u> TUBE (série PN6)	<u>Contact moulding</u> TUBE (STANDARD PN6)	STD N°101
<u>En roulement filamenteire</u> TUBE (série PN6)	<u>Orthogonal filament winding process</u> TUBE (standard PN6)	STD N°101A
REDUCTION CONCENTRIQUE	CONCENTRIC REDUCER	STD N°104
REDUCTION EXCENTRIQUE	ECCENTRIC REDUCER	STD N°105
COLLET A SOUDER	WELDED STUD ENDS	STD N°106
BRIDE MASSIVE	FIXED FLANGE	STD N°108
COUDE 90° RAYON=1.5d	90° ELBOW	STD N°109
COUDE 60° RAYON=1.5d	60° ELBOW	STD N°110
COUDE 45° RAYON=1.5d	45° ELBOW	STD N°111
COUDE30° RAYON=1.5d	30° ELBOW	STD N°112
BRIDE PLEINE	FLANGE	STD N°119

SVR catégorie "B"

Procédé de stratification : CONTACT

- (1) -Renforcé stratifié verre résine
 PMA : 6 bars jusqu'au DN400
 PMA : 4 bars jusqu'au DN600
 RT : 150 MPa (résistance à la traction du SVR)
 CS : 10 (coefficient de sécurité)

Process of manufacture : contact moulding

- (1) -Fibreglass Reinforced Polyester
 PMA : 6 bars up to DN400
 PMA : 4 bars up to DN600
 RT : 150 MPa (tensilestrength of FRP)
 CS : 10 (safety factor)

Au delà de 80°C s'assurer que la température maximale de service
 TMS \leq HDT de la résine employée.

-Exceeding 80°C, to make sure that the operating temperature maximum
 TMS \leq HDT of resin employed .

- (2) -Epaisseurs minimales de la couche de résistance mécanique
 (couche de finition exclue)

- (2) -Minimum thickness of mechanical strength layer
 (to exclude finishing layer)

Nota :

TMS: température maxi service
 (operating maximum temperature)

PMA : pression maxi admissible
 (pression maximum allowed)

HDT : température fléchissante sous charge
 (hight density temperature)

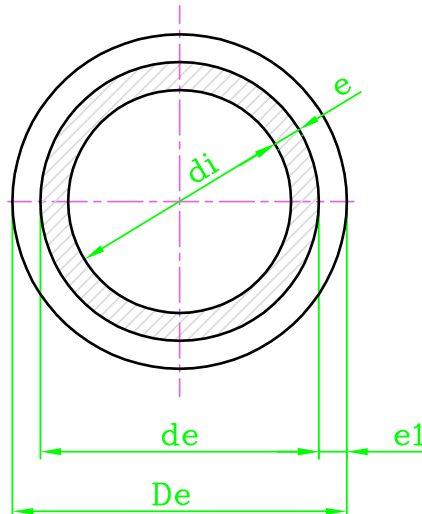

DIMENSION NOMINALE TUYAUTERIE		TUBE AC (AC: anti-corrosion)			COUCHE DE RESISTANCE MECANIQUE (1)		MASSE
DN	NS	de mm	di mm	e mm	e1 mm (2)	De mm	Kg/m
25	1"	31.6	25	3.3	3	37.6	0.88
32	1 1/4"	38.6	32	3.3	3	44.6	1.08
40	1 1/2"	46.6	40	3.3	3	52.6	1.31
50	2"	56.6	50	3.3	3	62.6	1.59
65	2 1/2"	71.6	65	3.3	4	79.6	2.40
80	3"	86.6	80	3.3	4	94.6	2.90
100	4"	106.6	100	3.3	4	114.6	3.57
125	5"	131.6	125	3.3	5	141.6	5.11
150	6"	156.6	150	3.3	5	166.6	6.06
200	8"	206.6	200	3.3	5	216.6	7.98
250	10"	256.6	250	3.3	6	268.6	11.24
300	12"	306.6	300	3.3	7	320.6	15.01
350	14"	356.6	350	3.3	8	372.6	19.30
400	16"	406.6	400	3.3	8	422.6	21.97
450	18"	456.6	450	3.3	8	472.6	24.64
500	20"	506.6	500	3.3	8	522.6	27.31
600	24"	606.6	600	3.3	9	624.6	35.78



Tubes série PN6

Pipes PN6

STANDARD: 101A

DATE: 13/03/06

PAGE: _____ REV: 0

SVR catégorie "B"

Procédé de stratification : ENROULEMENT FILAMENTAIRE Process of manufacture : filament winding process

(1) -Epaisseur anticorrosion : 2.5 ou 3 mm

(1) -Thickness of anticorrosion : 2.5 or 3 mm

(2) -Série : 6 bars 80° C

(2) -6 bars 80° C

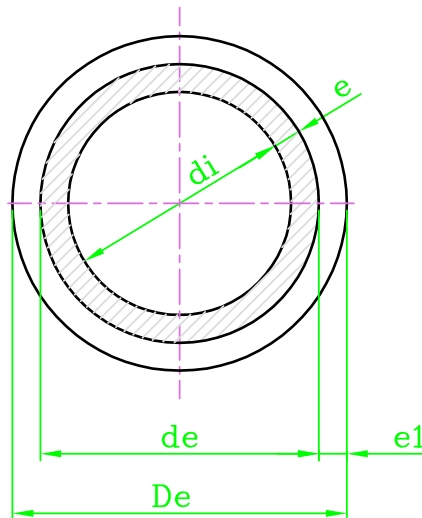

DIMENSION NOMINALE TUYAUTERIE		TUBE AC (AC: anti-corrosion)			COUCHE DE RESISTANCE MECANIQUE		MASSE
DN	NS	de mm	di mm	e (1) mm	e1 (2) mm	De mm	Kg/m
25	1"	30	25	2.5	2.2	34.4	0.70
32	1 1/4"	47	32	2.5	2.2	41.4	0.87
40	1 1/2"	45	40	2.5	2.2	49.4	1.06
50	2"	55	50	2.5	2.2	59.4	1.29
65	2 1/2"	70	65	2.5	2.2	74.4	1.64
80	3"	85	80	2.5	2.2	89.4	2.00
100	4"	105	100	2.5	2.2	109.4	2.46
125	5"	130	125	2.5	2.7	135.4	3.43
150	6"	155	150	2.5	3.2	161.4	4.54
200	8"	205	200	2.5	3.7	212.4	6.60
250	10"	255	250	2.5	4.3	263.6	9.08
300	12"	305	300	2.5	5.4	315.8	12.80
350	14"	355	350	2.5	5.8	366.6	15.70
400	16"	405	400	2.5	7.2	419.4	21.21
450	18"	455	450	2.5	8.6	472.2	27.52
500	20"	505	500	2.5	8.6	522.2	30.50
600	24"	605	600	2.5	10.1	625.2	41.76



Réductions concentriques

Concentric reducers

STANDARD: **104**

DATE: **13/03/06**

PAGE: _____ REV: **0**

SVR catégorie "B"

Procédé de stratification : CONTACT

-Pour les réductions, seule l'épaisseur anti-corrosion est réalisée .

-L'épaisseur de la couche résistance mécanique est déterminée suivant standard N°101

Process of manufacture: contact moulding

-For reducers, thickness of anti-corrosion is carried out only .

-Thickness of the mechanical strength layer is determined from standard N°101

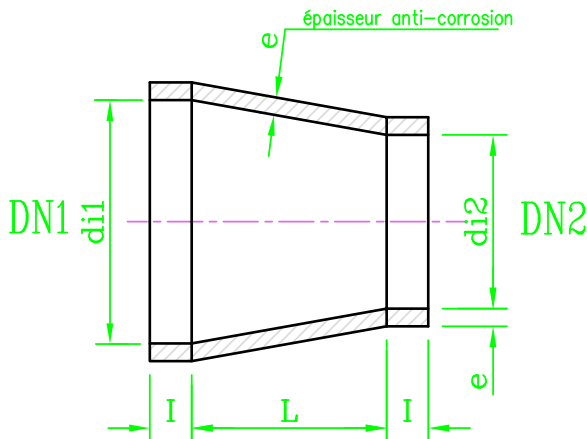

DIMENSION NOMINALE TUYAUTERIE		DIMENSION REDUCTION				
DN1	DN2	di1 mm	di2 mm	e mm	L mm	l mm
32	25	32	25	3.3	17	20
40	25	40	25	3.3	37	20
	32	40	32	3.3	20	
50	25	50	25	3.3	62	20
	32	50	32	3.3	45	
	40	50	40	3.3	25	
65	32	65	32	3.3	82	20
	40	65	40	3.3	62	
	50	65	50	3.3	37	
80	40	80	40	3.3	100	20
	50	80	50	3.3	75	
	65	80	65	3.3	37	
100	50	100	50	3.3	125	20
	65	100	65	3.3	87	
	80	100	80	3.3	50	
125	65	125	65	3.3	150	20
	80	125	80	3.3	112	
	100	125	100	3.3	62	
150	80	150	80	3.3	175	30
	100	150	100	3.3	125	
	125	150	125	3.3	62	
200	100	200	100	3.3	250	30
	125	200	125	3.3	187	
	150	200	150	3.3	125	
250	100	250	100	3.3	375	30
	125	250	125	3.3	312	
	150	250	150	3.3	250	
	200	250	200	3.3	125	
300	125	300	125	3.3	437	30
	150	300	150	3.3	375	
	200	300	200	3.3	250	
	250	300	250	3.3	125	
350	150	350	150	3.3	500	30
	200	350	200	3.3	375	
	250	350	250	3.3	250	
	300	350	300	3.3	125	
400	200	400	200	3.3	500	40
	250	400	250	3.3	275	
	300	400	300	3.3	250	
	350	400	350	3.3	125	
450	250	450	250	3.3	500	40
	300	450	300	3.3	375	
	350	450	350	3.3	250	
	400	450	400	3.3	125	
500	300	500	300	3.3	500	40
	350	500	350	3.3	375	
	400	500	400	3.3	250	
	450	500	450	3.3	125	
600	350	600	350	3.3	625	40
	400	600	400	3.3	500	
	450	600	450	3.3	375	
	500	600	500	3.3	250	

SVR catégorie "B"

Procédé de stratification : CONTACT

-Pour les réductions, seule l'épaisseur anti-corrosion est réalisée .

-L'épaisseur de la couche résistance mécanique est déterminée suivant standard N°101

Process of manufacture: contact moulding

-For reducers, thickness of anti-corrosion is carried out only .

-Thickness of the mechanical strength layer is determined from standard N°101

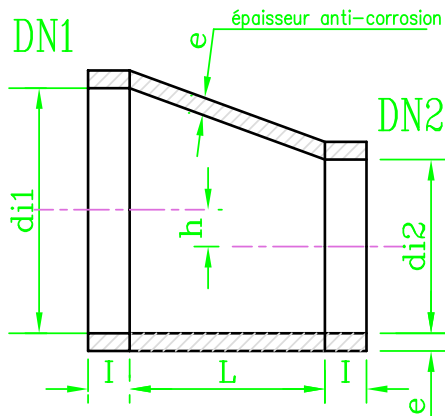

DIMENSION NOMINALE TUYAUTERIE		DIMENSION REDUCTION					
DN1	DN2	di1 mm	di2 mm	e mm	L mm	H mm	l mm
32	25	32	25	3.3	17	3.5	20
40	25	40	25	3.3	37	7.5	20
	32	40	32	3.3	20	4	
50	25	50	25	3.3	62	12.5	20
	32	50	32	3.3	45	9	
	40	50	40	3.3	25	5	
65	32	65	32	3.3	82	16.5	20
	40	65	40	3.3	62	12.5	
	50	65	50	3.3	37	7.5	
80	40	80	40	3.3	100	20	20
	50	80	50	3.3	75	15	
	65	80	65	3.3	37	7.5	
100	50	100	50	3.3	125	25	20
	65	100	65	3.3	87	17.5	
	80	100	80	3.3	50	10	
125	65	125	65	3.3	150	15	20
	80	125	80	3.3	112	22.5	
	100	125	100	3.3	62	12.5	
150	80	150	80	3.3	175	35	30
	100	150	100	3.3	125	25	
	125	150	125	3.3	62	12.5	
200	100	200	100	3.3	250	50	30
	125	200	125	3.3	187	37.5	
	150	200	150	3.3	125	25	
250	100	250	100	3.3	375	75	30
	125	250	125	3.3	312	62.5	
	150	250	150	3.3	250	50	
	200	250	200	3.3	125	25	
300	125	300	125	3.3	437	87.5	30
	150	300	150	3.3	375	75	
	200	300	200	3.3	250	50	
	250	300	250	3.3	125	25	
350	150	350	150	3.3	500	100	30
	200	350	200	3.3	375	75	
	250	350	250	3.3	250	50	
	300	350	300	3.3	125	25	
400	200	400	200	3.3	500	100	40
	250	400	250	3.3	275	75	
	300	400	300	3.3	250	50	
	350	400	350	3.3	125	25	
450	250	450	250	3.3	500	100	40
	300	450	300	3.3	375	75	
	350	450	350	3.3	250	50	
	400	450	400	3.3	125	25	
500	300	500	300	3.3	500	100	40
	350	500	350	3.3	375	75	
	400	500	400	3.3	250	50	
	450	500	450	3.3	125	25	
600	350	600	350	3.3	625	125	40
	400	600	400	3.3	500	100	
	450	600	450	3.3	375	75	
	500	600	500	3.3	250	50	

SVR catégorie "B"

Procédé de stratification : CONTACT

-Les dimensions du SVR sont celles du collet B2 de la DIN 16966 partie 6 tableau 6 (sauf DN125 et cote N1 des DN200-DN250-DN300-DN400)

-Les dimensions constituent le minimum admissible pour : PMA : 6 bars (avec dérogation à la DIN pour le DN350 et DN400)

-Au delà de 80°C s'assurer que la température maximale de service TMS \leq HDT de la résine employée.

Process of manufacture : contact moulding

-The dimensions of FRP are those of the collar B1 of the DIN 16966 part 6 table 6 (excepted DN125 et cote N1 des DN200-DN250-DN300-DN400)

-The dimensions constitute the minimum allowed for : PMA : 6 bars (dispensation for DN350 et DN400)

-Exceeding 80°C, to make sure that the operating temperature maximum TMS \leq HDT of resin employed .

Bride tournante acier voir standard 505
Bride tournante SVR voir standard 505A
(loose flange in carbon steel see standard 505)
(loose flange in FRP see standard 505A)

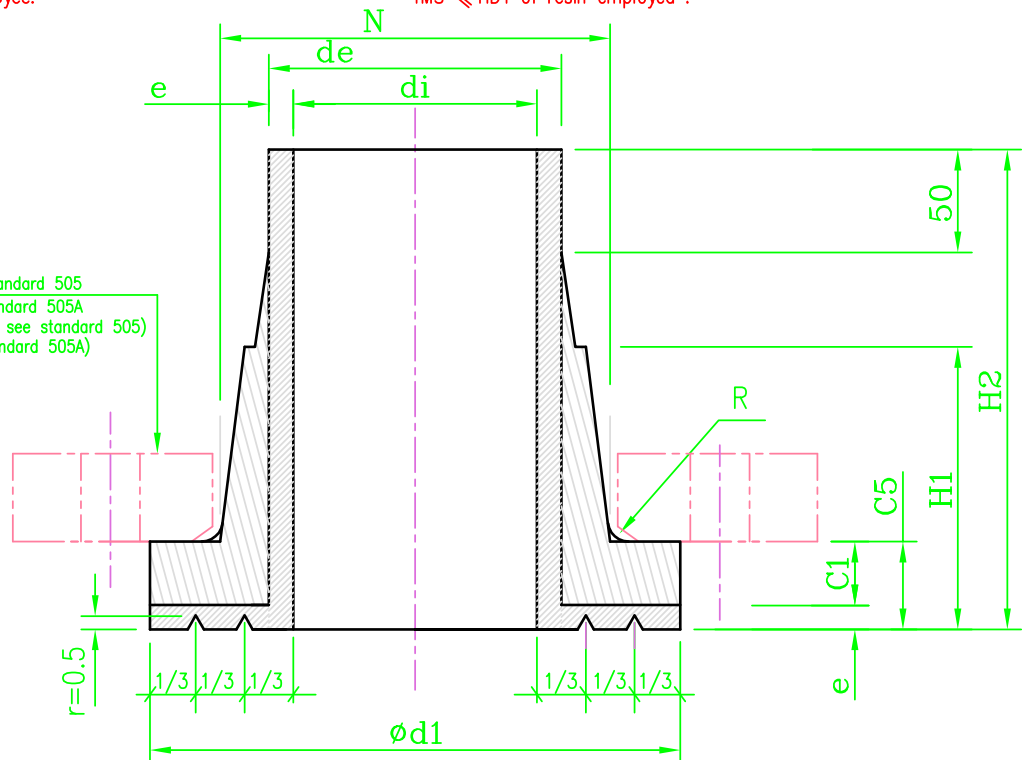

DIMENSION NOMINALE TUYAUTERIE		TUBE AC (AC: anti-corrosion)			COLLET						
DN	NS	de mm	di mm	e mm	Ød1 mm	C1 mm	C5 mm	H1 mm	H2 mm	N mm	R mm
20	3/4"	26.6	20	3.3	58	11.7	15	33	160	40	3
25	1"	31.6	25	3.3	68	11.7	15	33	160	50	3
32	1 1/4"	38.6	32	3.3	78	13.7	17	35	160	58	3
40	1 1/2"	46.6	40	3.3	88	13.7	17	38	160	68	3
50	2"	56.6	50	3.3	102	13.7	17	43	160	82	3
65	2 1/2"	71.6	65	3.3	122	14.7	18	47	160	95	3
80	3"	86.6	80	3.3	138	15.7	19	51	160	111	3
100	4"	106.6	100	3.3	158	17.7	21	58	160	133	4
125	5"	131.6	125	3.3	188	19.7	23	67	210	164	4
150	6"	156.6	150	3.3	212	21.7	25	74	210	188	4
200	8"	206.6	200	3.3	268	24.7	28	88	210	237	5
250	10"	256.6	250	3.3	320	27.7	31	104	260	293	5
300	12"	306.6	300	3.3	370	29.7	33	119	260	343	5
350	14"	356.6	350	3.3	430	31.7	35	136	310	387	6
400	16"	406.6	400	3.3	482	34.7	38	150	310	441	6

SVR catégorie "B"

Procédé de stratification : CONTACT

-Les dimensions du SVR sont celles de la bride V3 de la DIN 16966 partie 6 tableau 2 (sauf pour les DN125 et DN350 et 600)

-Les dimensions constituent le minimum admissible pour :
PMA : 6 bars jusqu'au DN400 (avec dérogation pour DN350, DN400)
PMA : 4 bars jusqu'au DN600 (avec dérogation pour DN600)
(PMA : pression maxi admissible)

-Au delà de 80°C s'assurer que la température maximale de service TMS \leq HDT de la résine employée.

Process of manufacture : contact moulding

-The dimensions of FRP are those of the flange V3 of the DIN 16966 part 6 table 2 (except DN125, DN350, DN600)

-The dimensions constitute the minimum allowed for :
PMA : 6 bars up to DN400 (with dispensation for DN350, DN400)
PMA : 4 bars up to DN600 (with dispensation for DN600)
(PMA : pression maximum allowed)

-Exceeding 80°C, to make sure that the operating temperature maximum TMS \leq HDT of resin employed .

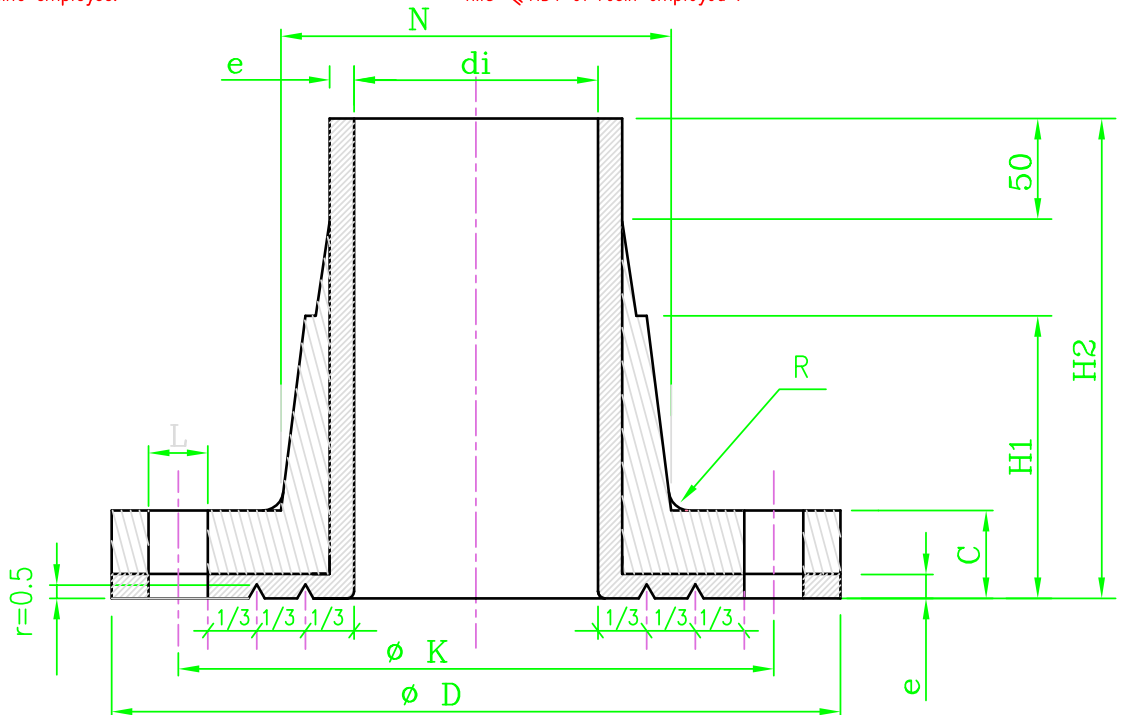

DIMENSION NOMINALE TUYAUTERIE		BRIDE PERCAGE ISO PN10										
DN	NS	di mm	e mm	ØD mm	nbr trous	ØL mm	ØK mm	C mm	H1 mm	H2 mm	N mm	R mm
20	3/4"	20	3.3	Ø105	4 trous	Ø14	Ø75	15	31	160	42	3
25	1"	25	3.3	Ø115	4 trous	Ø14	Ø85	17	33	160	50	3
32	1 1/4"	32	3.3	Ø140	4 trous	Ø18	Ø100	18	35	160	58	3
40	1 1/2"	40	3.3	Ø150	4 trous	Ø18	Ø110	19	38	160	68	3
50	2"	50	3.3	Ø165	4 trous	Ø18	Ø125	21	43	160	82	3
65	2 1/2"	65	3.3	Ø185	4 trous	Ø18	Ø145	23	47	160	95	3
80	3"	80	3.3	Ø200	8 trous	Ø18	Ø160	25	51	160	111	3
100	4"	100	3.3	Ø220	8 trous	Ø18	Ø180	27	58	160	133	4
125	5"	125	3.3	Ø250	8 trous	Ø18	Ø210	30	67	210	167	4
150	6"	150	3.3	Ø285	8 trous	Ø22	Ø240	33	74	210	188	4
200	8"	200	3.3	Ø340	8 trous	Ø22	Ø295	36	83	210	245	5
250	10"	250	3.3	Ø395	12 trous	Ø22	Ø350	40	93	260	300	5
300	12"	300	3.3	Ø445	12 trous	Ø22	Ø400	45	103	260	350	5
350	14"	350	3.3	Ø505	16 trous	Ø22	Ø460	46	105	260	410	6
400	16"	400	3.3	Ø565	16 trous	Ø26	Ø515	47	108	310	460	6
450	18"	450	3.3	Ø615	20 trous	Ø26	Ø565	49	115	310	503	6
500	20"	500	3.3	Ø670	20 trous	Ø26	Ø620	52	123	310	565	6
600	24"	600	3.3	Ø780	20 trous	Ø30	Ø725	56	128	310	660	7

SVR catégorie "B"

Procédé de stratification : CONTACT

Process of manufacture : contact moulding

-Epaisseurs déterminées à partir du standard N°101 avec au moins un tissu supplémentaire pour la couche résistance mécanique .

-Thickness determined from standard N°101 with at least an additional E glass roving for the mechanical strength layer

-Les coudes < au DN125, seule l'épaisseur anti-corrosion est réalisée .

-Elbows < to DN125, thickness of anti-corrosion is carried out only .

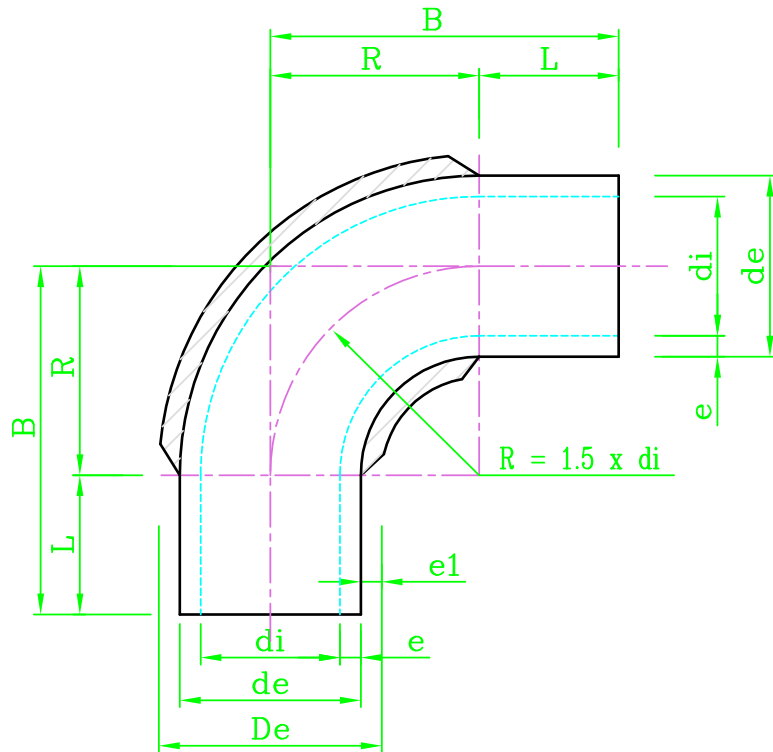

DIMENSION NOMINALE TUYAUTERIE		TUBE AC (AC: anti-corrosion)			COUCHE DE RESISTANCE MECANIQUE		COUDE CINTRE 90°		
DN	NS	de mm	di mm	e mm	e1 mm	De mm	R mm	B mm	L mm
25	1"	31.6	25	3.3	3	37.6	37	57	20
32	1 1/4"	38.6	32	3.3	3	44.6	48	68	20
40	1 1/2"	46.6	40	3.3	3	52.6	60	80	20
50	2"	56.6	50	3.3	3	62.6	75	95	20
65	2 1/2"	71.6	65	3.3	4	79.6	97	117	20
80	3"	86.6	80	3.3	4	94.6	120	140	20
100	4"	106.6	100	3.3	4	114.6	150	170	20
125	5"	131.6	125	3.3	5	141.6	187	207	20
150	6"	156.6	150	3.3	5	166.6	225	255	30
200	8"	206.6	200	3.3	5	216.6	300	330	30
250	10"	256.6	250	3.3	6	268.6	375	405	30
300	12"	306.6	300	3.3	7	320.6	450	480	30
350	14"	356.6	350	3.3	8	372.6	525	555	30
400	16"	406.6	400	3.3	8	422.6	600	640	40
450	18"	456.6	450	3.3	8	472.6	675	715	40
500	20"	506.6	500	3.3	8	522.6	750	790	40
600	24"	606.6	600	3.3	9	624.6	900	940	40

SVR catégorie "B"

Procédé de stratification : CONTACT

-Epaisseurs déterminées à partir du standard N°101 avec au moins un tissu supplémentaire pour la couche résistance mécanique .

-Les coudes < au DN125, seule l'épaisseur anti-corrosion est réalisée .

Process of manufacture : contact moulding

-Thickness determined from standard N°101 with at least an additional E glass roving for the mechanical strength layer

-Elbows < to DN125, thickness of anti-corrosion is carried out only .

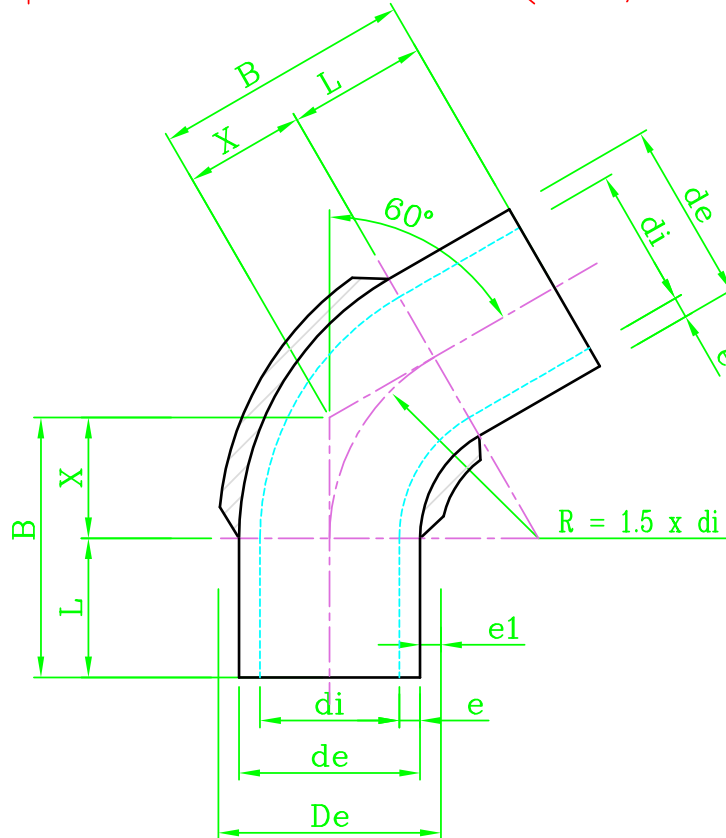

DIMENSION NOMINALE TUYAUTERIE		TUBE AC (AC: anti-corrosion)			COUCHE DE RESISTANCE MECANIQUE		COUDE CINTRE 60°			
DN	NS	de mm	di mm	e mm	e1 mm	De mm	R mm	B mm	X mm	L mm
25	1"	31.6	25	3.3	3	37.6	37	41	21	20
32	1"1/4	38.6	32	3.3	3	44.6	48	48	28	20
40	1"1/2	46.6	40	3.3	3	52.6	60	55	35	20
50	2"	56.6	50	3.3	3	62.6	75	63	43	20
65	2"1/2	71.6	65	3.3	4	79.6	97	76	56	20
80	3"	86.6	80	3.3	4	94.6	120	89	69	20
100	4"	106.6	100	3.3	4	114.6	150	107	87	20
125	5"	131.6	125	3.3	5	141.6	187	128	108	20
150	6"	156.6	150	3.3	5	166.6	225	160	130	30
200	8"	206.6	200	3.3	5	216.6	300	203	173	30
250	10"	256.6	250	3.3	6	268.6	375	247	217	30
300	12"	306.6	300	3.3	7	320.6	450	290	260	30
350	14"	356.6	350	3.3	8	372.6	525	333	303	30
400	16"	406.6	400	3.3	8	422.6	600	378	338	40
450	18"	456.6	450	3.3	8	472.6	675	430	390	40
500	20"	506.6	500	3.3	8	522.6	750	473	433	40
600	24"	606.6	600	3.3	9	624.6	900	560	520	40

SVR catégorie "B"

Procédé de stratification : CONTACT

-Epaisseurs déterminées à partir du standard N°101 avec au moins un tissu supplémentaire pour la couche résistance mécanique .

-Les coudes < au DN125, seule l'épaisseur anti-corrosion est réalisée .

Process of manufacture : contact moulding

-Thickness determined from standard N°101 with at least an additional E glass roving for the mechanical strength layer

-Elbows < to DN125, thickness of anti-corrosion is carried out only .

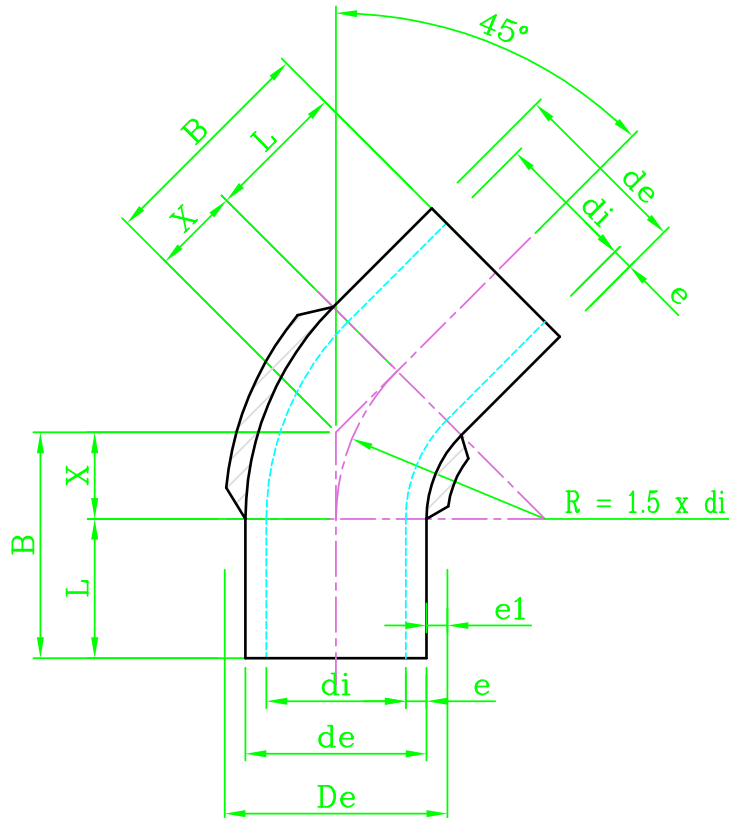

DIMENSION NOMINALE TUYAUTERIE		TUBE AC (AC: anti-corrosion)			COUCHE DE RESISTANCE MECANIQUE		COUDE CINTRE 45°			
DN	NS	de mm	di mm	e mm	e1 mm	De mm	R mm	B mm	X mm	L mm
25	1"	31.6	25	3.3	3	37.6	37	35	15	20
32	1"1/4	38.6	32	3.3	3	44.6	48	40	20	20
40	1"1/2	46.6	40	3.3	3	52.6	60	45	25	20
50	2"	56.6	50	3.3	3	62.6	75	51	31	20
65	2"1/2	71.6	65	3.3	4	79.6	97	60	40	20
80	3"	86.6	80	3.3	4	94.6	120	70	50	20
100	4"	106.6	100	3.3	4	114.6	150	82	62	20
125	5"	131.6	125	3.3	5	141.6	187	98	78	20
150	6"	156.6	150	3.3	5	166.6	225	123	93	30
200	8"	206.6	200	3.3	5	216.6	300	154	124	30
250	10"	256.6	250	3.3	6	268.6	375	185	155	30
300	12"	306.6	300	3.3	7	320.6	450	216	186	30
350	14"	356.6	350	3.3	8	372.6	525	248	218	30
400	16"	406.6	400	3.3	8	422.6	600	289	249	40
450	18"	456.6	450	3.3	8	472.6	675	320	280	40
500	20"	506.6	500	3.3	8	522.6	750	351	311	40
600	24"	606.6	600	3.3	9	624.6	900	413	373	40

SVR catégorie "B"

Procédé de stratification : CONTACT

-Epaisseurs déterminées à partir du standard N°101 avec au moins un tissu supplémentaire pour la couche résistance mécanique .

-Les coudes < au DN125, seule l'épaisseur anti-corrosion est réalisée .

Process of manufacture : contact moulding

-Thickness determined from standard N°101 with at least an additional E glass roving for the mechanical strength layer

-Elbows < to DN125, thickness of anti-corrosion is carried out only .

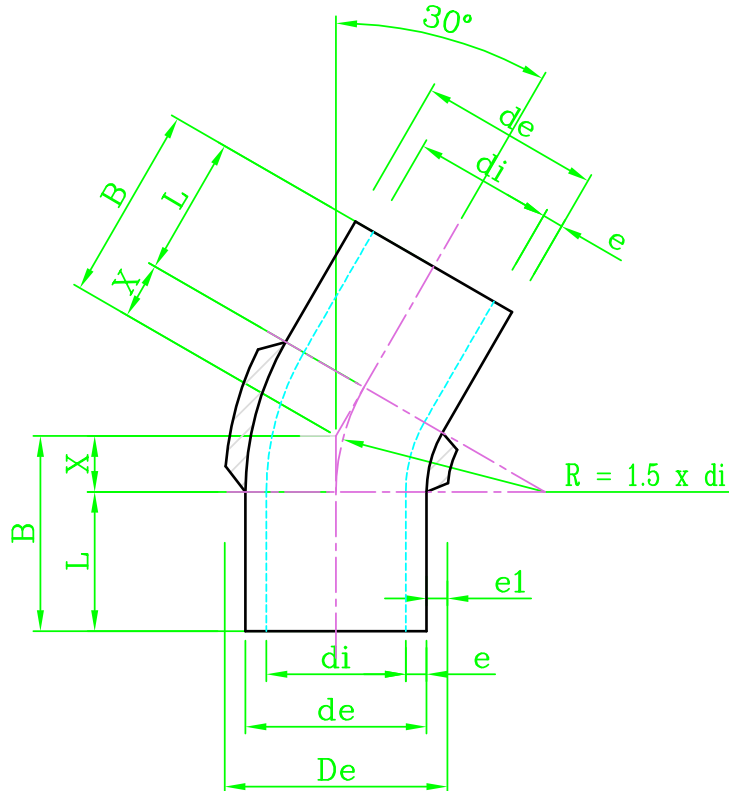

DIMENSION NOMINALE TUYAUTERIE		TUBE AC (AC: anti-corrosion)			COUCHE DE RESISTANCE MECANIQUE		COUDE CINTRE 30°			
DN	NS	de mm	di mm	e mm	e1 mm	De mm	R mm	B mm	X mm	L mm
25	1"	31.6	25	3.3	3	37.6	37	30	10	20
32	1"1/4	38.6	32	3.3	3	44.6	48	32	12	20
40	1"1/2	46.6	40	3.3	3	52.6	60	36	16	20
50	2"	56.6	50	3.3	3	62.6	75	40	20	20
65	2"1/2	71.6	65	3.3	4	79.6	97	46	26	20
80	3"	86.6	80	3.3	4	94.6	120	52	32	20
100	4"	106.6	100	3.3	4	114.6	150	60	40	20
125	5"	131.6	125	3.3	5	141.6	187	70	50	20
150	6"	156.6	150	3.3	5	166.6	225	90	60	30
200	8"	206.6	200	3.3	5	216.6	300	110	80	30
250	10"	256.6	250	3.3	6	268.6	375	130	100	30
300	12"	306.6	300	3.3	7	320.6	450	150	120	30
350	14"	356.6	350	3.3	8	372.6	525	170	140	30
400	16"	406.6	400	3.3	8	422.6	600	200	160	40
450	18"	456.6	450	3.3	8	472.6	675	220	180	40
500	20"	506.6	500	3.3	8	522.6	750	240	200	40
600	24"	606.6	600	3.3	9	624.6	900	282	242	40

SVR catégorie "B"

Procédé de stratification : CONTACT

-Les dimensions constituent le minimum admissible pour :

PMA : 6 bars jusqu'au DN400

PMA : 4 bars jusqu'au DN600

(PMA : pression maxi admissible)

-Au delà de 80°C s'assurer que la température maximale de service
TMS ≤ HDT de la résine employée.

Process of manufacture : contact moulding

-The dimensions constitute the minimum allowed for :

PMA : 6 bars up to DN400

PMA : 4 bars up to DN600

(PMA : pression maximum allowed)

-Exceeding 80°C, to make sure that the operating temperature maximum
TMS ≤ HDT of resin employed .

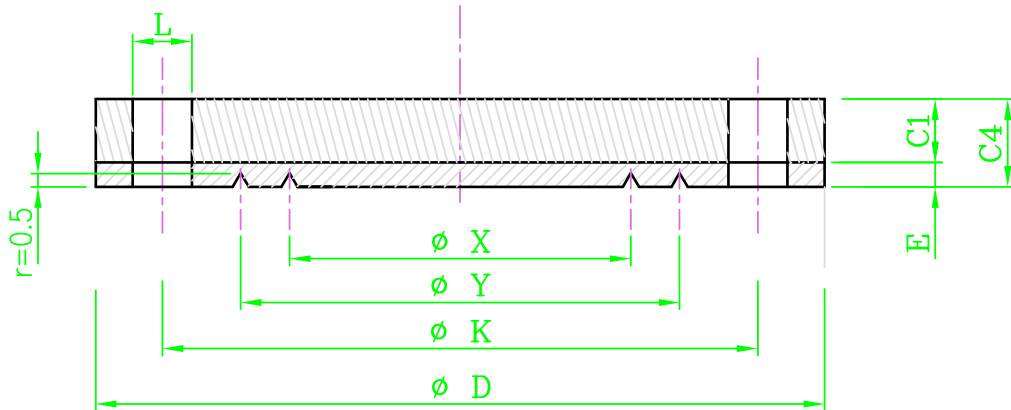

DIMENSION NOMINALE TUYAUTERIE		BRIDE PLEINE PERCAGE ISO PN10								
DN	NS	ØD mm	nbr trous	ØL mm	ØK mm	ØX mm	ØY mm	E mm	C1 mm	C4 mm
20	3/4"	Ø105	4 trous	Ø14	Ø75	34	47	3.3	24.7	28
25	1"	Ø115	4 trous	Ø14	Ø85	40	56	3.3	24.7	28
32	1"1/4	Ø140	4 trous	Ø18	Ø100	49	65	3.3	29.7	33
40	1"1/2	Ø150	4 trous	Ø18	Ø110	58	75	3.3	29.7	33
50	2"	Ø165	4 trous	Ø18	Ø125	69	88	3.3	29.7	33
65	2"1/2	Ø185	4 trous	Ø18	Ø145	86	108	3.3	29.7	33
80	3"	Ø200	8 trous	Ø18	Ø160	100	121	3.3	31.7	35
100	4"	Ø220	8 trous	Ø18	Ø180	121	141	3.3	31.7	35
125	5"	Ø250	8 trous	Ø18	Ø210	148	170	3.3	31.7	35
150	6"	Ø285	8 trous	Ø22	Ø240	173	195	3.3	34.7	38
200	8"	Ø340	8 trous	Ø22	Ø295	224	249	3.3	34.7	38
250	10"	Ø395	12 trous	Ø22	Ø350	276	302	3.3	39.7	43
300	12"	Ø445	12 trous	Ø22	Ø400	326	352	3.3	44.7	48
350	14"	Ø505	16 trous	Ø22	Ø460	379	409	3.3	49.7	53
400	16"	Ø565	16 trous	Ø26	Ø515	430	460	3.3	54.7	58
450	18"	Ø615	20 trous	Ø26	Ø565	480	509	3.3	49.7	53
500	20"	Ø670	20 trous	Ø26	Ø620	531	563	3.3	54.7	58
600	24"	Ø780	20 trous	Ø30	Ø725	631	662	3.3	64.7	68